

GROUP

a

PREFACE

We are constantly surrounded by man-made spaces resulting from geometric planes that are either horizontal or vertical, and we normally hang art objects on these surfaces or place art objects in the resulting spaces. Our purpose with this exhibition is to look at these same architectural surfaces and spaces in a fresh way so that they do not become mere backgrounds for objects but, as artistic statements, become an inherent part of the organic whole. We have asked participating artists to transform these surfaces and spaces, in two or three dimensions, to create subjective responses within the confines of these surroundings. Our aim has been to expand the current visual, physical, and psychological limitations of architectural environments not normally considered the province of the artist.

Arts & Crafts Center Fifth & Shady Avenues Pittsburgh Pennsylvania 13 September — 5 October 1980

WALLS CEILINGS FLOORS SPACES

GALLERY

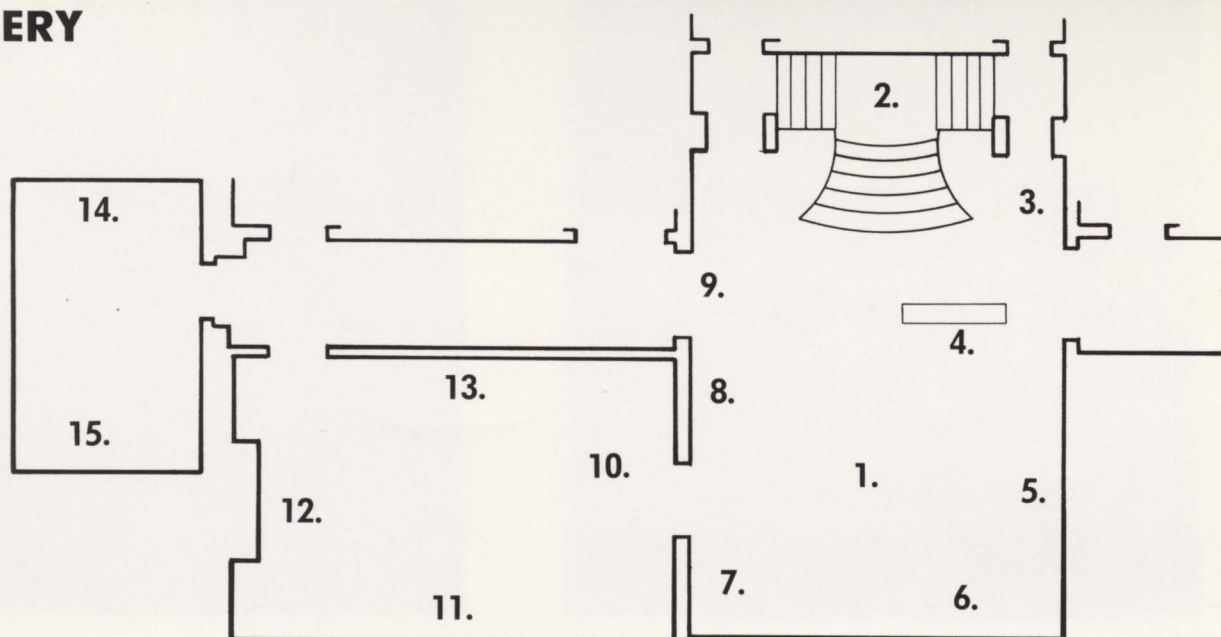

ARTISTS

- | | |
|--|---|
| <p>1 STURGEON, Everett
FIN POTS (Individually sold \$52, \$60, \$96)
Ceramic</p> | <p>9 CAPLAN, Jerry
ARCH OF COLOR (\$3000)
A watercolor ambience</p> |
| <p>2 SAMUELS, Diane
LINE ON STAIRS (\$300)
Papier Mache, rubber bands, wood</p> | <p>10 SUNNERGREN, Anna M.
THE CHICKEN LITTLE RUN (\$750)
Fabric</p> |
| <p>3 KARN, Gloria
TO BEGIN AGAIN (\$1100)
Thermoform construction</p> | <p>11 HOLLEN-BOLMGREN, Donna
SCULPTURED WALL (\$2000)
Handmade cast paper environmental collage
Suspended masks are for the viewers' participation</p> |
| <p>4 HENSCHER, David
UNTITLED (Price on request)
Wood, metal</p> | <p>12 PASINSKI, Irene
A SQUARE DEAL (\$1500)
Wood, Diffraction gratings</p> |
| <p>5 HALTER Katrina
MODEL FOR A WALL INSERT (\$500)
Canvas on wood</p> | <p>13 DESMETT, Ron & MULCAHY, Kathleen
DOUBLE SELF PORTRAIT (\$1000)
Wood plaster, metal, cloth</p> |
| <p>6 WEILAND, Cris
GROUP FORCE (Price on request)
Wood</p> | <p>14 HORNELL, Lori
UNTITLED (Price on request)
Fiber</p> |
| <p>7 GRUBER, Aaronel de Roy
IT'S A CORNER (\$1200)
Rope, wood, mirror</p> | <p>15 WOOLF, David
UNDULATIONS (\$400)
Polyester, tungsten light, particle board</p> |
| <p>8 GRAPER, Marion
ARTS & CRAFTS CENTER RETROSPECTIVE (\$1000)
Mixed media</p> | |

We wish to thank:

TASSO KATSELAS, Architectural consultant for the exhibition
MARK PERROTT, Photographs
SUPERIOR LITHO, INC., Printing

SPONSORS

Anonymous Friends
Arts & Crafts Center
M. A. Baskind Co.
Mr. & Mrs. Anthony J. A. Bryan
The Design Center,
Baum Boulevard at Morewood
Pittsburgh National Bank
Adrienne & Milton Porter
Westinghouse Electric Corporation

PATRONS

Mr. & Mrs. William Block
Mrs. S. E. Bramer
Mr. & Mrs. Milton Fine
Mr. & Mrs. James A. Fisher
Mr. & Mrs. Jay L. Foster
Mr. James A. Frank
Ms. Mary Glick, Outlines, Inc.
Dr. & Mrs. Raymond W. Goldblum
Adrian & Harvey Hoechstetter
Mr. Paul Kossman
Mr. & Mrs. Donald M. Robinson
Adele & J. Karl Stark



1

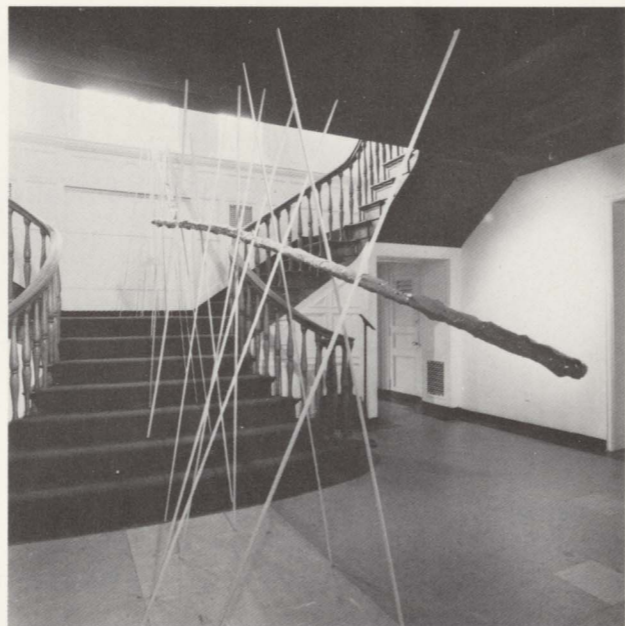

2

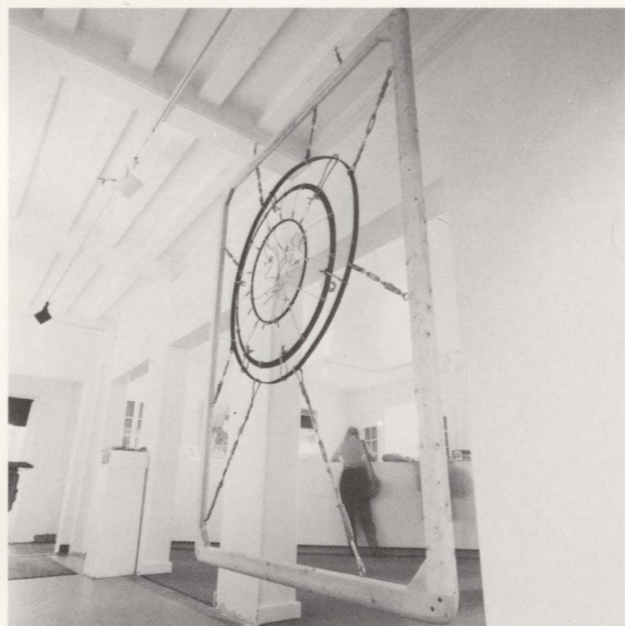

4

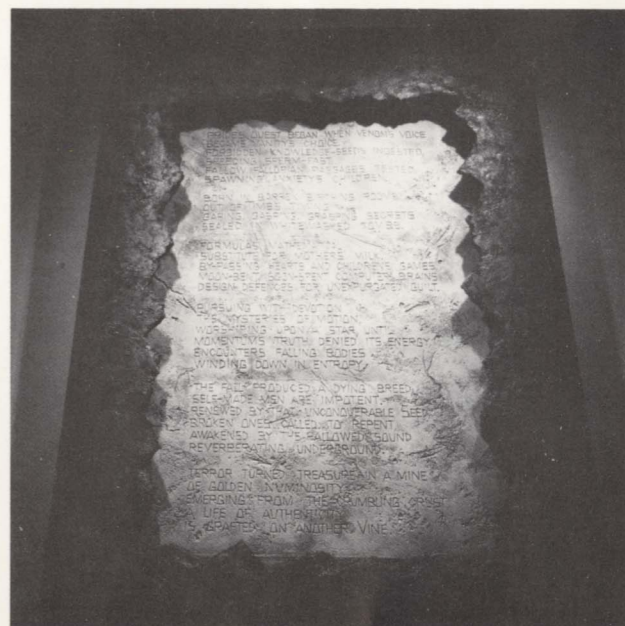

3

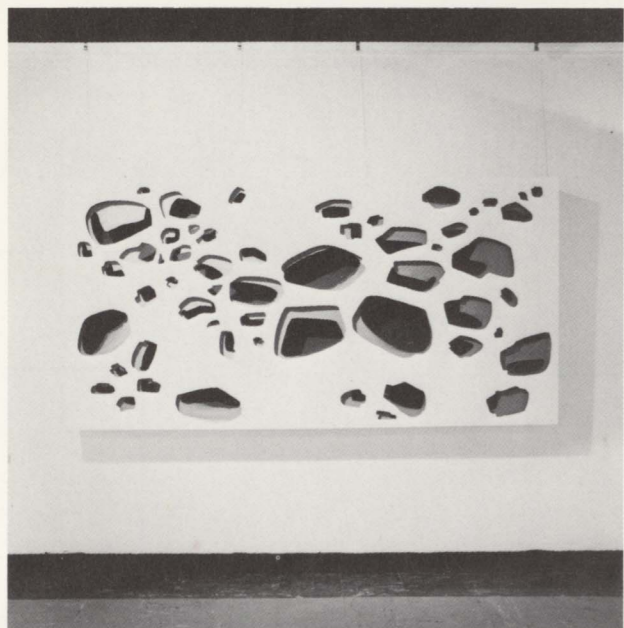

5

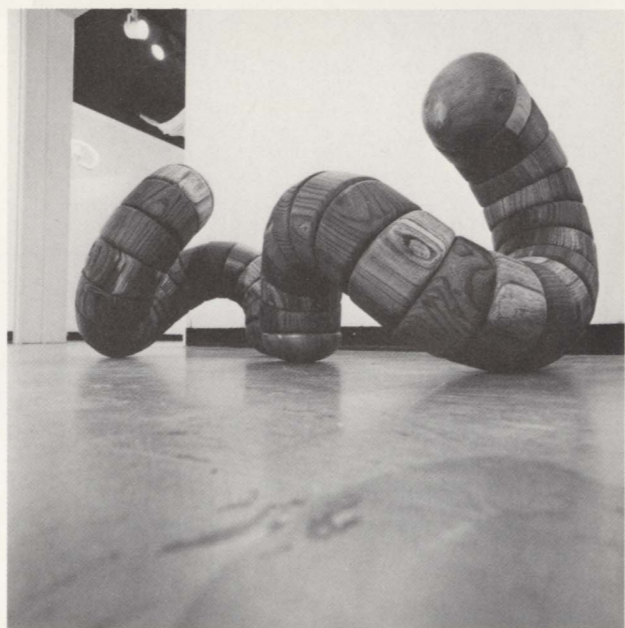

6

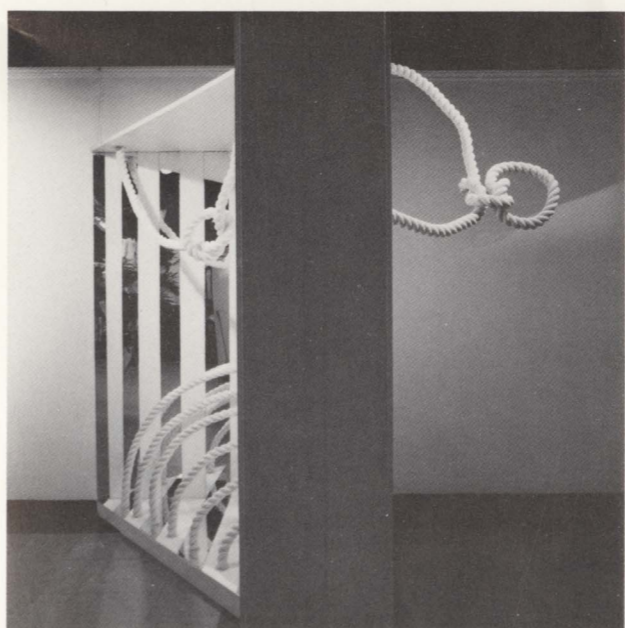

7

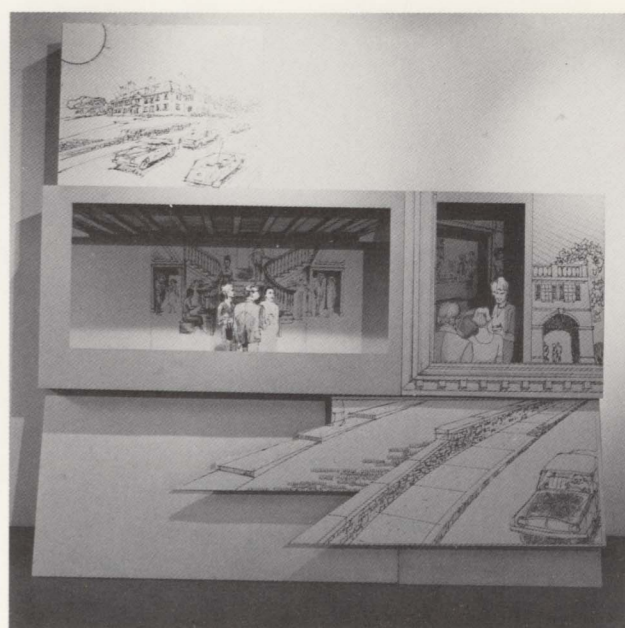

8



9

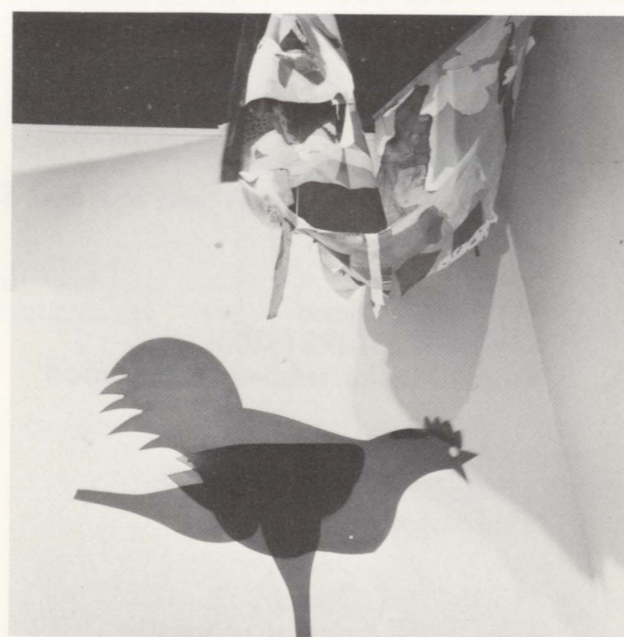

10



11

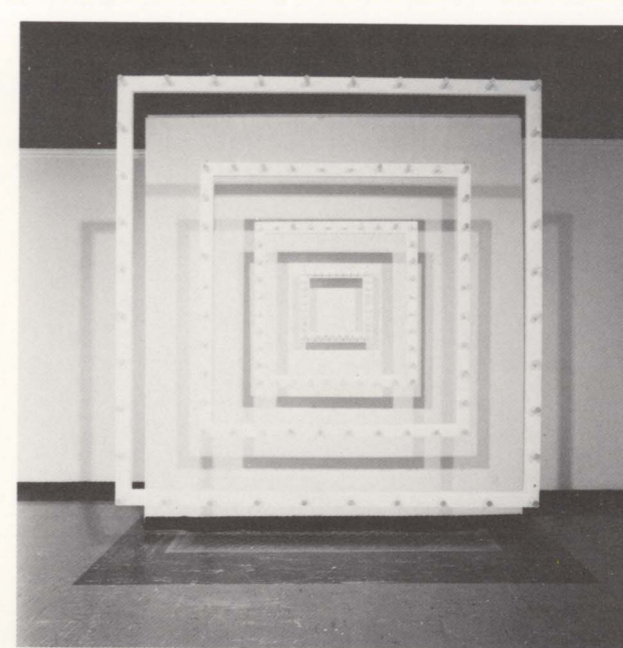

12



13

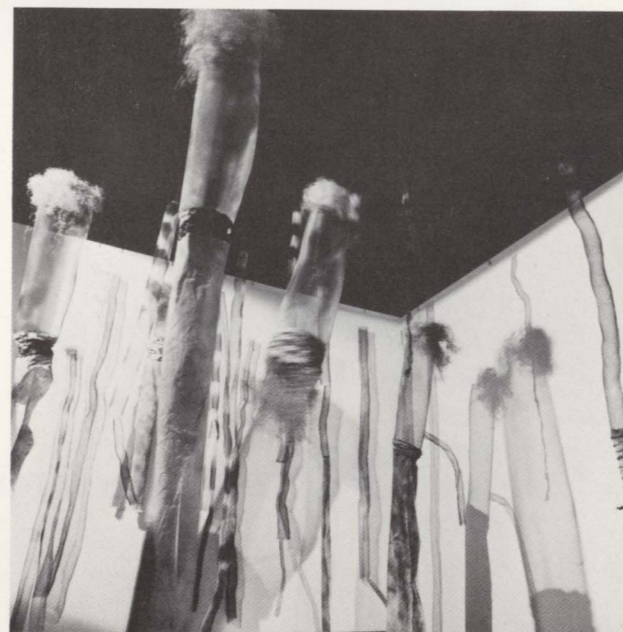

14

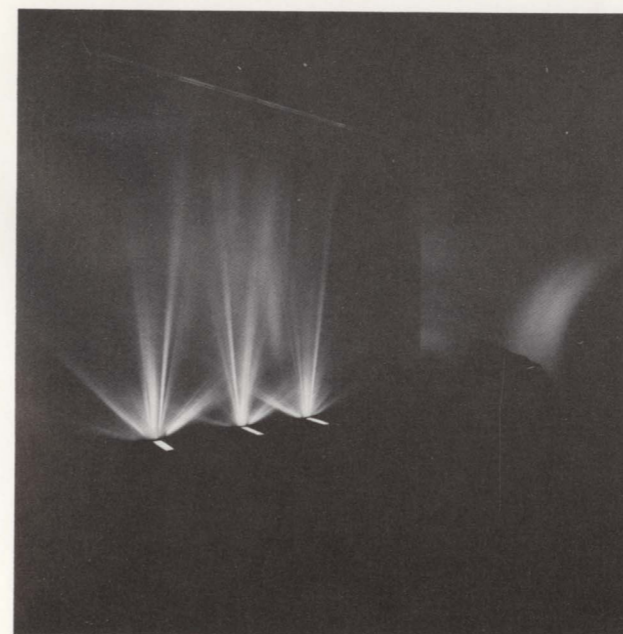

15

1. Everett Sturgeon
2. Diane Samuels
3. Gloria Karn
4. David Henschel
5. Katrina Halter
6. Cris Weiland
7. Aaronel de Roy Gruber
8. Marion Graper
9. Jerry Caplan
10. Anna M. Sunnergren
11. Donna Hollen-Bolmgren
12. Irene Pasinski
13. Ron Desmett & Kathleen Mulcahy
14. Lori Hornel
15. David Woolf

For Group A

Aaronel de Roy Gruber, President
David Henschel, Vice President
Irene Pasinski, Secretary
Lori Hornell, Treasurer

Everett Sturgeon, Table decorations
Anna M. Sunnergren, Food
Gloria Karn, Coordination
Marion Graper, Drawings and model
Aaronel de Roy Gruber, Fund raising
Irene Pasinski, Fund raising
Donna Hollen-Bolmgren, Publicity
Harry Grant, Graphics